

**Junckers Clip Sports Floor System**

D 1.0 General Information

D 1.1 Clip Sports Information

**D 2.1 Specifier's Information**

D 2.1.1 Laying Instructions

**Components**

**1 - Boards**

- Junckers 22 mm solid boards.  
 Wood species and grades:  
 Beech, SylvaKet, Maple and Ash /  
 Classic and Harmony.  
 Surfaces → B 2.0

Thickness x width x Length:  
 22 x 129 x 3700 / 1830 mm

**2 - Clips**

- 25-50% RH: 129.1 mm/1 hole
- 35-65% RH: 129.4 mm/2 hole
- 60-85% RH: 129.8 mm/3 hole

**3 - Intermediate layer**

- 5 mm resilient mat, extruded polyethylene cellular plastic, density 35 kg/m<sup>3</sup>
- 10 mm resilient mat, extruded polyethylene cellular plastic, density 35 kg/m<sup>3</sup>

**4 - Moisture barrier on concrete**

- Min. 0.20 mm PE membrane

**5 - Header joint adhesive**

- Junckers water-based SylvaFix header joint adhesive.

**6 - Junckers expansion strip**

- Height x Width x Length: 20 x 12 x 2000 mm  
 For floors up to 25 m in length:  
 1 expansion strips per wall-end  
 For floors up to 50 m in length:  
 2 expansion strips per wall-end

**7 - Distance to wall**

- 2 mm per m of floor width on each side, min. 30 mm.  
 Is also required at fixed points, e.g. columns.

Fig. 2

**General description of floor system**

Junckers Clip Sports Floor System is based on 22 mm solid boards laid as a floating floor with clips on a resilient foam underlay. The floor system is an area elastic type of sports floor with medium shock absorbency and elasticity particularly suitable for fitness and aerobics as well as in refurbishment projects. The construction height is 27 mm or 32 mm, depending on the thickness of the foam underlay.

Please note that full documentation of a floor system comprises the data in D 1.0, D 1.1, 2.1 and D 2.1.1.

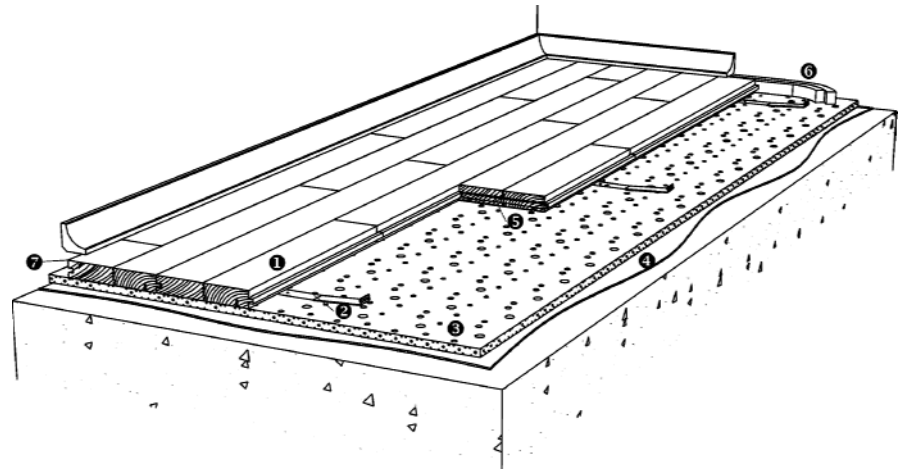

Fig. 3

**System specifications**

The clip system is installed as a floating floor on a dry, load-bearing floor of concrete, lightweight concrete or wooden materials, e.g. an existing sports floor.

The subfloor must be flat with a maximum deviation of 2 mm under a 1.5 m straight edge (UK: 3mm under a 3 m straight edge). The surface must be smooth. Any minor irregularities must be corrected. The choice of intermediate layer depends on the structure of the subfloor and the moisture conditions.

**Boards**

Boards are laid in a continuous, irregular pattern, with header joints distributed randomly across the entire floor. To avoid waste, the off cut from the last completed row can be used to start a following row.

**Resilient mat/intermediate layer**

The choice of resilient mat depends on the properties of the subfloor. If the subfloor is fully or partly inelastic a 10 mm resilient mat is used, while for elastic subfloors, e.g. existing sports floors with certain resilient properties, a 5 mm mat is used.

**Clips**

Clips are available in several sizes, according to the various humidity ranges. The clip size is chosen on the basis of the maximum expected relative humidity in the building in the course of the year. To minimise the overall measurements of large floor surfaces it can be necessary to choose a larger clip size than corresponding to the expected maximum humidity. →Table 1.

Clip type (label colour)	Humidity range	Clip size	Gap between boards
1 hole (green)	25 - 50 %	129.1 mm	Approx. 0.1 mm gap
2 hole (yellow)	35 - 65 %	129.4 mm	Approx. 0.4 mm gap
3 hole (red)	60 - 85 %	129.8 mm	Approx. 0.8 mm gap

Table 1

Clip consumption: 17 clips/m<sup>2</sup>

**Moisture barrier**

On ground floors and where there is a risk of moisture penetration a moisture barrier of 0.20 mm PE membrane is laid directly on the concrete.

**Load-bearing strength**

The load-bearing strength of the clip system depends on the load and subfloor type. The floor's total transverse expansion can also play a role, depending on the climate conditions in the hall and the clip size.

Table 2 shows use of the floor system in relation to the load classes in DS 410/ENV 1991-2-1:1995. For further definition of load classes and types,

→ D 1.0 - Stiffness and bearing strength.









Table of loadings	ENV :1995		Other loads		Explanation of symbols
	Area load	Point load	Wheel load (solid)	Wheel load (air)	
<b>Loading types</b>    					● Loadings conforming to the requirements of ENV 1991-2-1:1995 and deflection criterion ◆ Wheel loads on concrete conforming to D 1.0 - Table 2
<b>Loading category</b> C4 Areas with possible physical activities C5 Areas susceptible to overcrowding					<b>Remarks</b> 1) Point load area min. 200 x 200 mm

Table 2

**Floor rosettes**

Floor rosettes must be mounted so that both vertical and horizontal movement of the floor is unimpeded. The internal diameter of the flange must exceed that of the pipe, i.e. the external diameter of the net pole, by minimum 40 mm. At the outer zones of the floor all flanges are mounted eccentrically towards the centre of the floor in relation to the bush fittings in the concrete → Fig. 4.

**Consumption of materials**

**Net consumption for 1000 m<sup>2</sup> Clip Sports Floor System**

- Boards: 1000 m<sup>2</sup> + approx. 2% wastage
  - Clips: 17000 pcs.
  - Resilient mat: 1000 m<sup>2</sup>
  - Junckers SylvaFix header joint adhesive: 15 litres
  - Junckers expansion strip: 4 x floor width
  - Optional moisture barrier (always on concrete), min. 0.20 mm PE membrane: 1100 m<sup>2</sup> incl. overlaps
- For halls with many columns, etc. extra clip consumption must be included in the estimated consumption.

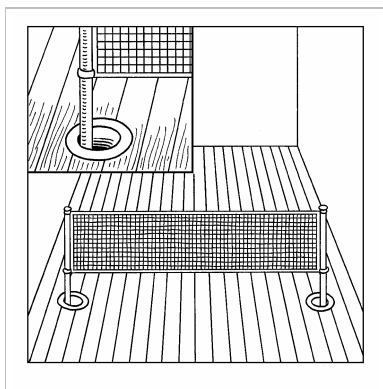

Fig. 4